

FITTING THE PONTUS SECONDARY SCRAPER 9500

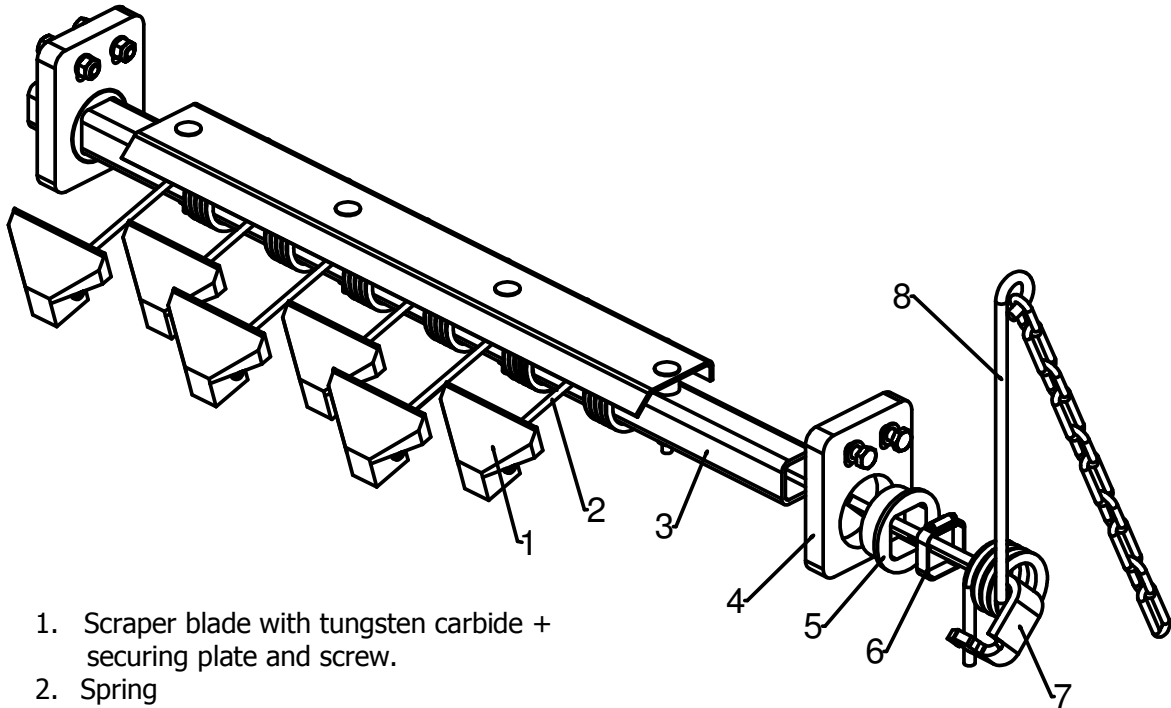

1. Scraper blade with tungsten carbide + securing plate and screw.
2. Spring
3. Beam
4. Holder H
5. PU-bushing
6. Hose clamp
7. Fixing plate for lever arm
8. Torsion lever arm and chain with snap hook and toothed washer.

B-W 1000 and up have lever arms on both sides.

GENERAL INFORMATION

The Pontus 9500 is a secondary scraper with a tungsten-carbide blade encapsulated in polyurethane. All blades are mounted on an individual spring. The Pontus is designed for heavy industry with stringent cleaning requirements. The scraper has a simple design with a minimum of moving parts.

IMPORTANT

In order to achieve the best scraping results, the following conditions must be met:

The conveyor belt must be free of damage. The belt may otherwise catch on the scraper segments (1), resulting in a breakdown.

The conveyor belt must be flat. If the belt has a tendency to bulge, fit a return roller (sheet-metal roller) a few decimetres from the scraper, with function of a "pressure-roller".

The scraper must not be fitted to chevron belts or belts with mechanical joints.

Max. belt speed: 2.3 m/s

Max. temperature: + 50°C in wet environments

Max. temperature: + 85°C in dry environments (ambient temperature + frictional heat)

CAUTION

Always turn off the belt conveyor before installing or carrying out maintenance on the scraper.

Make sure that the belt cannot start while this work is in progress.

FITTING

1.	The scraper is placed below the drive pulley with the tips as shown in the drawing.
2.	Slip the holders (4), the PU-bushes (5) and the hose clamps (6) onto the beam (3)
3.	Make two mounting plates (=flat bars with two holes $\varnothing 11$ mm). Weld these to the frame in the position that the centre of the beam is approx. 90 mm under the conveyor belt
4.	The scraper is bolted to the mounting plates using the bolts supplied.
5.	Centre the scraper on the pulley and lock the beam laterally using hose clamps. Cut the beam to suitable length.
6.	Mount the torsion lever arm (8) onto the fixing plate (7). Make sure that the short spring pin locks in the notch on the fixing plate.
7.	Insert the fixing plate (7) in the beam (3). Drill a hole ($\varnothing 7$ mm) right through the square tube and lock the fixing plate (7) using an M6 x 50 mm bolt
8.	Weld the toothed washer to the frame. Set the lever arm (8). and hook the snap hook onto the washer. Find the optimal pressure, this is often low, by trial and error.

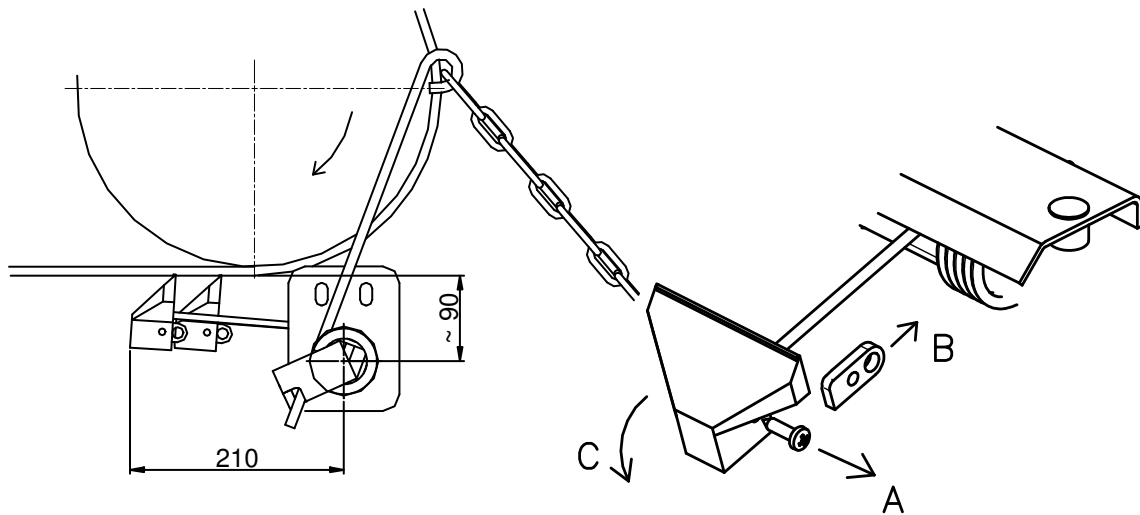

MAINTENANCE

Inspect and clean the scraper regularly– we suggest once a week.

When 1 mm of the tungsten carbide remains, change all the segments (1).

To change to new blades. It is only take away the screw (A) on the scraper blade – and pull out the securing plate (B), the blade can now easily be removed from the spring (C).

Assembly the scraper in the opposite order. Pre stress the scraper.

Readjust the scraper pressure so as to achieve optimal cleaning. There must be no vibrations or noise. However, vibrations may arise when the belt is running without material or when the belt has a coating of resin. In the long term, vibrations may result in cracking of the beam. Vibrations must therefore be eliminated. Try therefore:

..... changing the angle of the blade against the belt a few degrees

..... changing the pressure of the blade against the belt.

..... making a more robust attachment to the frame.

..... increasing the mass of the beam (3) by, for example, fitting a small lever arm to the beam.

WARRANTY

Damage to the scraper caused by incorrect handling or in connection with incorrect installation cannot be considered to be covered by warranty if these instructions have not been followed. We therefore accept no claims for any consequential damage or loss.